

● Diaphragm jaws

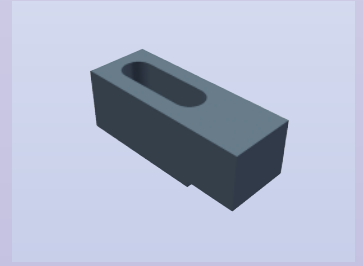

DIAPHRAGM JAWS WITH SLIDERS MALE SLOT

	A h6	D	E	F	G	H	I	L	M	N	O	Weight
	mm	mm	mm	mm	mm	mm	mm	mm	mm	mm	mm	kg
01582	30	30	9	14	10	82	14	31	14	59	3	0.43
01583	20	25	7	11	10	70	12	26	12	50	5	0.21

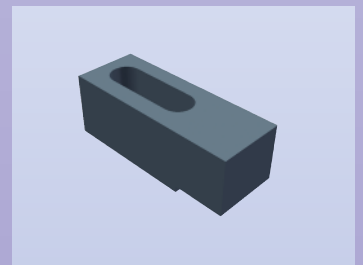
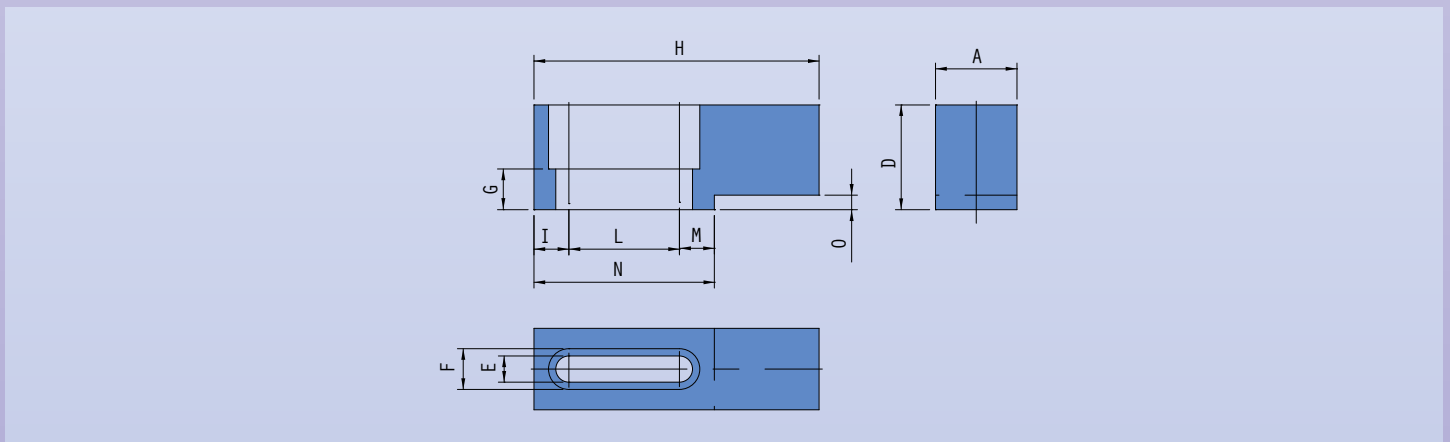

DIAPHRAGM JAWS WITH SLIDERS FEMALE SLOT

												mm	mm	kg
01584	15	4	28	36	9	14	14	98	12	38	18	68	5	0.52
01585	20	4	38	38	11	17	14	110	15	44	20	79	5	0.83
01923	15	4	25	28	7	11	13	70	10	32	16	58	5	0.26

